

Sandvik BR5011i series

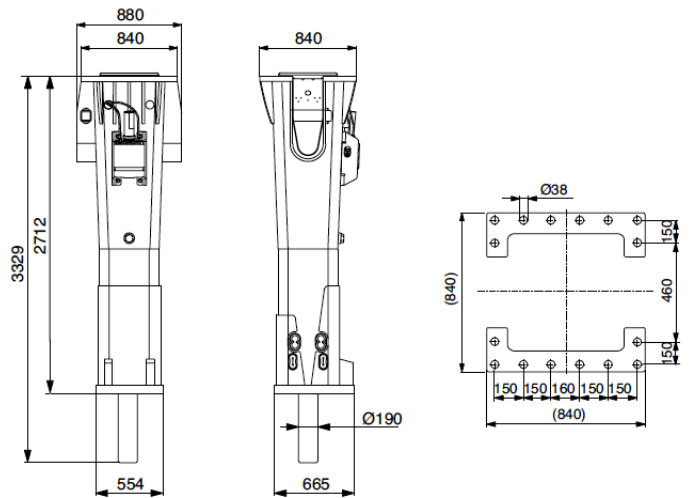

Optimum productivity with every blow

Harness the power of data to maximize the hammer's uptime and performance.

Factory-installed RD3

Remote monitoring device for superior fleet management

Best power-weight ratio in the market

Reduced fuel usage for optimum productivity and more savings in money.

Durable like no other

Extreme durability for any application to ensure longest life span.

Product specifications	
Minimum working weight, flange mounted, kg (lb)	4750 (10470)
Impact rate, bpm	370-530
Operating pressure, bar (psi)	160-170 (2320-2465)
Pressure relief, max bar (psi)	230 (3335)
Oil flow range, l/min (gal/min)	280-380 (74.0-100.4)
Back pressure, max bar (psi)	10 (145)
Input power, kW (hp)	108 (145)
Tool diameter, mm (in)	190 (7.48)
Miniexcavator weight, allowed range t (lb)	43-80 (94800-176400)
Skid steer, robot weight, allowed range t (lb)	-
Noise level, measured sound power level, LWA dB	122
Noise level, guaranteed sound power level, LWA dB	126

Sandvik Mining and Rock Solutions reserves the right to make changes to the information on this data sheet without prior notification to users. Please contact a Sandvik representative for clarification on specifications and options.

Sandvik Mining and Rock Solutions © 2024.

Legal notice: All trademarks and logos appearing in this material are owned by the Sandvik Group of companies, unless otherwise specifically indicated.