

## LinaClass® SLO Linear Motion Vibrating Screens

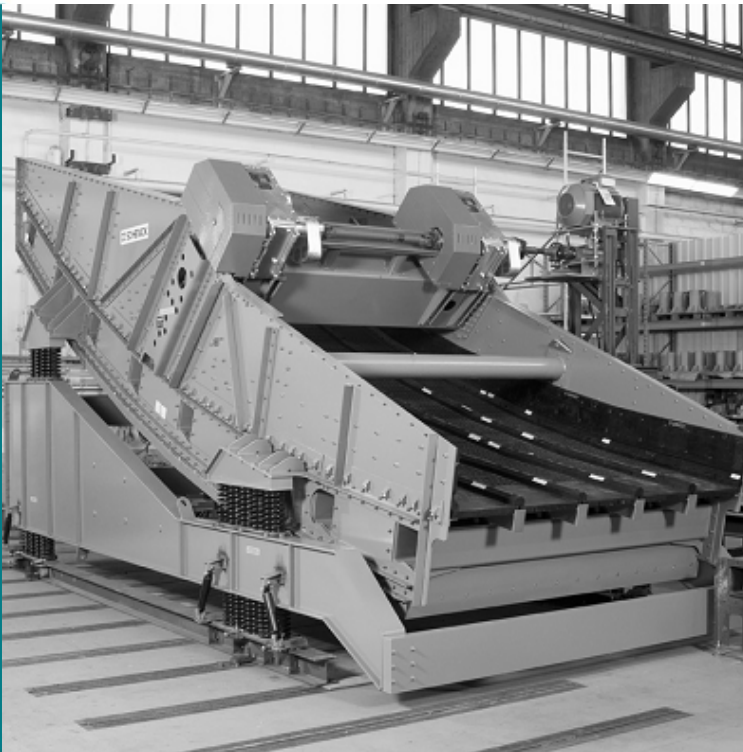

### Classifying of bulk materials such as:

- Ore
- Coal
- Sinter
- Pellets
- Coke
- Limestone
- Aggregates
- Sand and Gravel
- etc.

### Application

LinaClass SLO 'Banana Screens' are used to screen large quantities of materials with a high content of fine particles. Higher inclines in the feed area keep the height of the bulk material layer low as a result of a high conveying speed. This means an increase in throughput which allows larger feed quantities. The near-mesh material is screened out in the final third section of the screening machine. Their rugged design ensures a high degree of operating reliability and availability, even under harsh conditions.

### Design

LinaClass® SLO screens owe their name to the banana-shaped arrangement of the screen mats. They are characterized by well-engineered design and a high quality standard. The components are fixed together with bolts and rivets. SLO screens are designed for use with screen mats made of polyurethane (PU), rubber, wire or perforated plates. These screen mats can be easily replaced. Subassemblies such as side walls and hollow shaped cross beams are protected against wear and tear.

### Function

All LinaClass SLO model vibrating screens are equipped with the reliable Directed Force Exciter (model DF) and are based on the micro throw principle. The vibrating screens perform a linear movement at an angle of impact to the horizontal, generating the movement of the material. Overcritical systems are applied. This enables the vibrating screen to be operated stably and makes it extremely insensitive to unsteady loads.

## All the advantages at a glance:



### Directed Force Exciter DF

- Minimal service required thanks to oil lubrication
- Lubrication with standard mineral oil - oil change required every 1,000 operating hours
- Fast and uncomplicated replacement of the entire drive unit
- Long lifetime, high availability
- Requires only 1 standard motor
- After-Sales Service for exciter with Schenck Process guarantee



### Machine Spring Suspension and Isolation Frame

- Low dynamic foundation loads
- Coil springs with linear spring characteristic (constant ratio between load and spring deflection)
- Isolation frames with hydraulic shock absorbers optional for larger machines or for machines installed in vibration-sensitive buildings to reduction by up to 90 % of dynamic forces transmitted into the steel structure and the foundations



### Hollow Shaped Cross Beams and Exciter Bearer

- Hollow shaped cross beams ensure maximum rigidity, optimal force transmission and minimum weight
- Heat treatment subsequent to welding relieves internal stresses
- Machining of all joining areas after heat treatment results in high accuracy of fit and low tolerances, minimizing component stresses during assembly

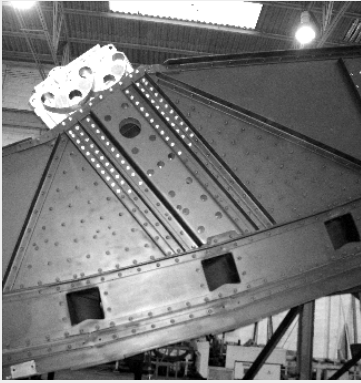

### Side Wall Connections

- Side wall stiffeners, hollow shaped cross beams and exciter bearer riveted using the Huck method with lockbolts
- Vibration-insensitive connections, high constant pre-stressing, very low-maintenance (no re-tightening of bolts)
- Lockbolts can be loosened mechanically if necessary
- No welding on the side wall in order to avoid internal stresses



### Test Runs

- Factory test runs for several hours of all screen machines and exciters before delivery
- Analysis of the natural frequencies in order to avoid damage from operating frequencies in this region
- Adjustment of all vibration data (amplitude)
- Securing of a accurate and failure-free operation of the screens from the start



### Wear Protection

- Optimal wear protection of the hollow cross beams and side walls given by exchangeable wear materials suited to the bulk material
- Wear lining can be made of rubber, PU, ceramic, etc.
- Rapid and uncomplicated exchange thanks to the use of screwed-in components

**Single-deck type:**

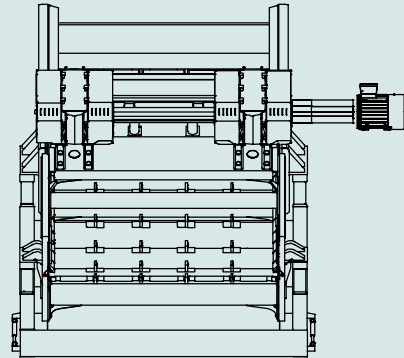
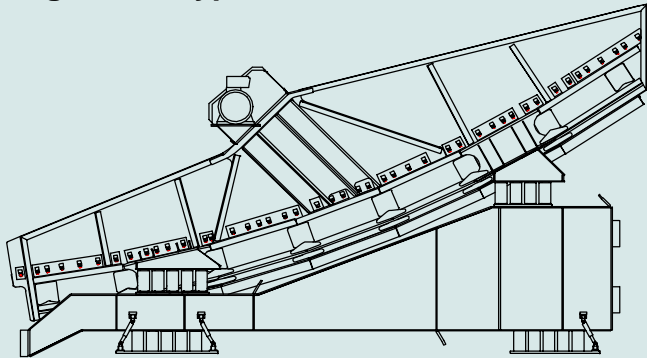

**Double-deck type:**

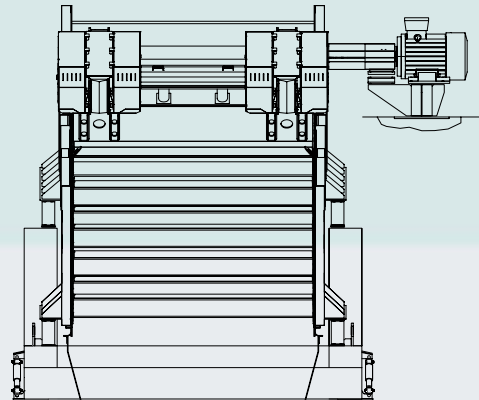
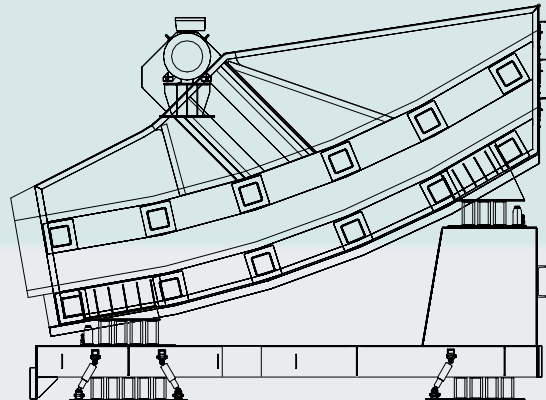

**Technical Data:**

Width	[mm]	1.300 - 4.500
Length	[mm]	4.800 - 10.800
Capacity	[t/h]	up to 3.000
Cutpoint	[mm]	up to 100

Don't forget our other LinaClass® models.

**Schenck Process GmbH**  
 Pallaswiesenstr. 100  
 64293 Darmstadt, Germany  
 Phone: +49 6151 1531-1216  
 Fax: +49 6151 1531-1172  
 sales@schenckprocess.com  
 www.schenckprocess.com